

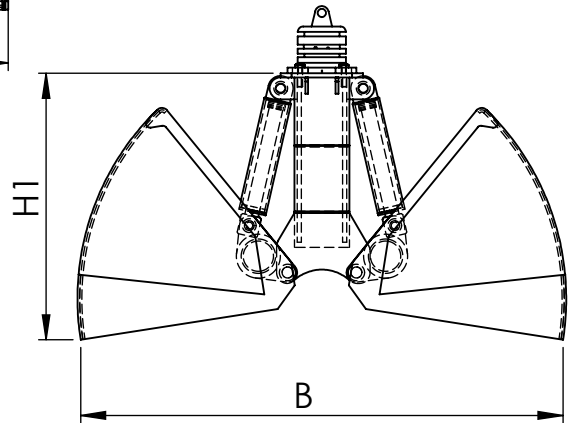

APR
cranes

HYDARULIC CLAM SHELL GRAB BUCKET

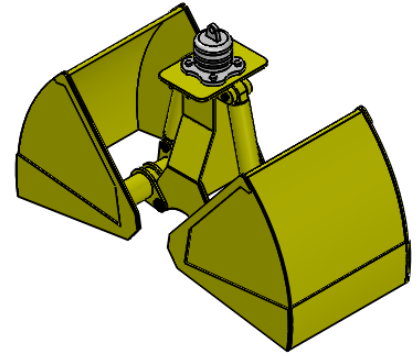
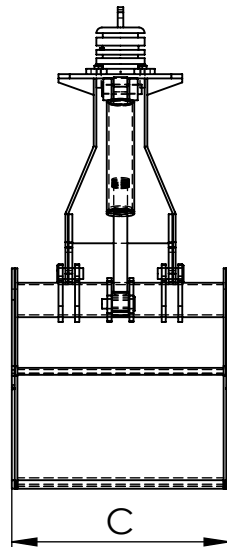
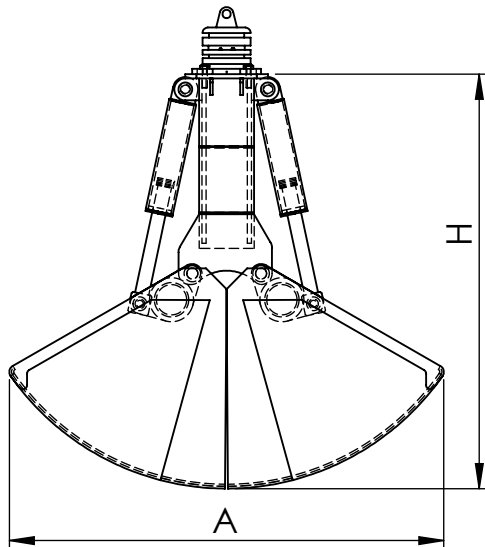

DIMENSION FOR OUR DIFFERENT MODELS

Capacity m ³	Working pressure Bar	Aprox Weight kg.	Dimensions in mm				
			A	B	C	H	H1
0.75	160 To 180	1500	1700	1850	855	1730	1125
1	161 To 180	1800	1875	2130	935	1896	1225
1.5	162 To 180	2150	2185	2445	1020	2105	1340
2.5	180 To 200	2950	2535	2815	1250	2541	1740
5	181 To 200	4300	3160	3510	1580	3115	1934
6	182 To 200	5050	3335	3760	1700	3305	2032

MATERIAL OF CONSTRUCTION

PIN & AXLES : En 8
 KNIFE EDGES : HARDOX 400/500
 GRAB MATERIAL : ST - 52 / Q345B / Sailma - 350

APR BRIGHT INDUSTRIES
PLOT NO. 102, EPIP-1 JHARMAJRI, BADDI (H.P)
MOB.NO. 09816400039 Email - aprbright@gmail.com